

SCOPE ITEMS (SEQ. #1700)
A3.04, A8.05 DECORATIVE SLATS (ALUMINUM)
MATERIALS SPECIFICATION
ANGLE: L3X3X1/4 (ALUM. - 6061-T6) SLAT PANEL : FL1/2"X6" SOLID BAR (ALUM. - 6061-T6511)

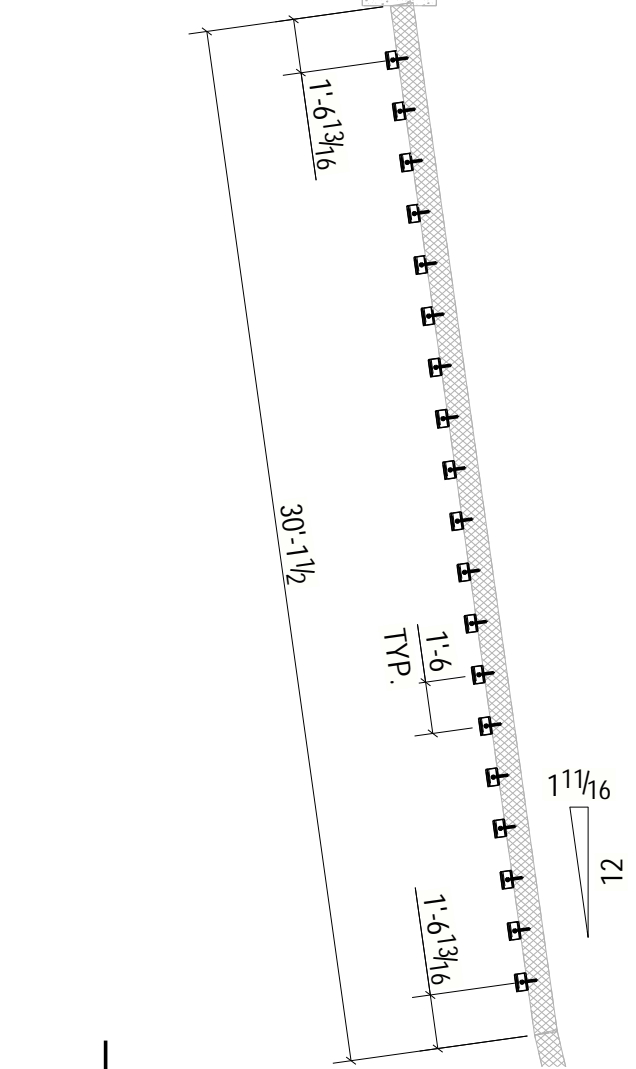

1 DECORATIVE ALUMINUM SLATS LAYOUT
SCALE: 1:64

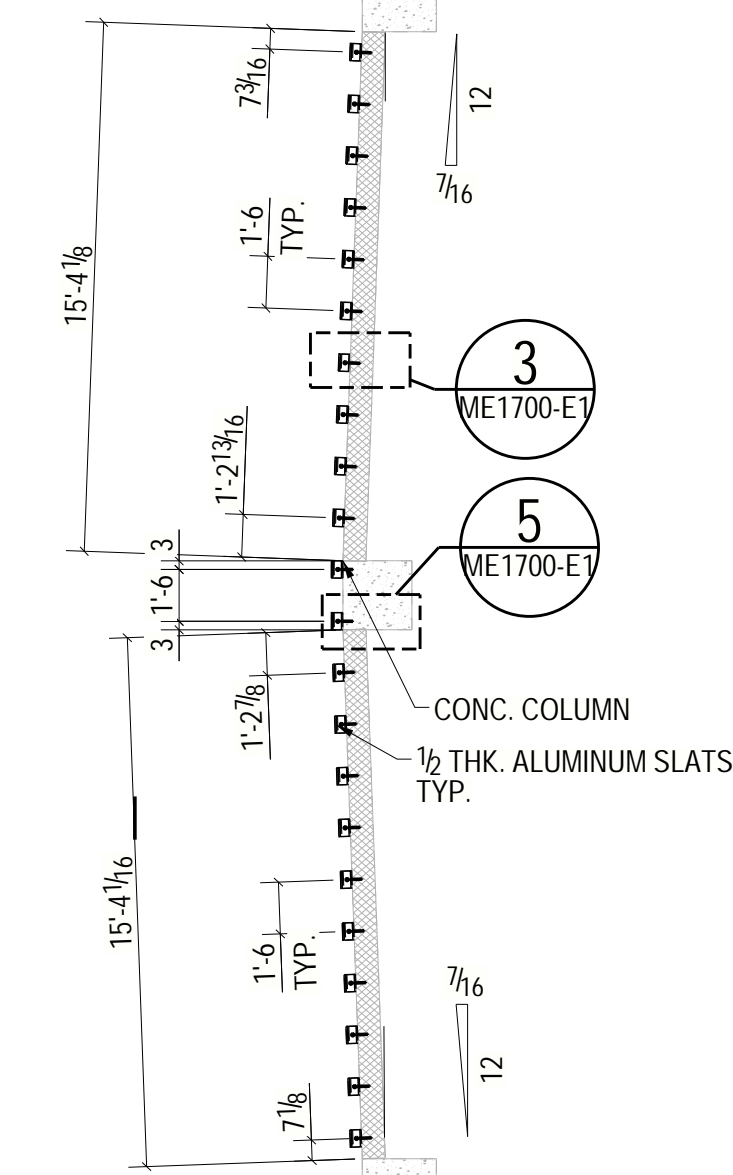
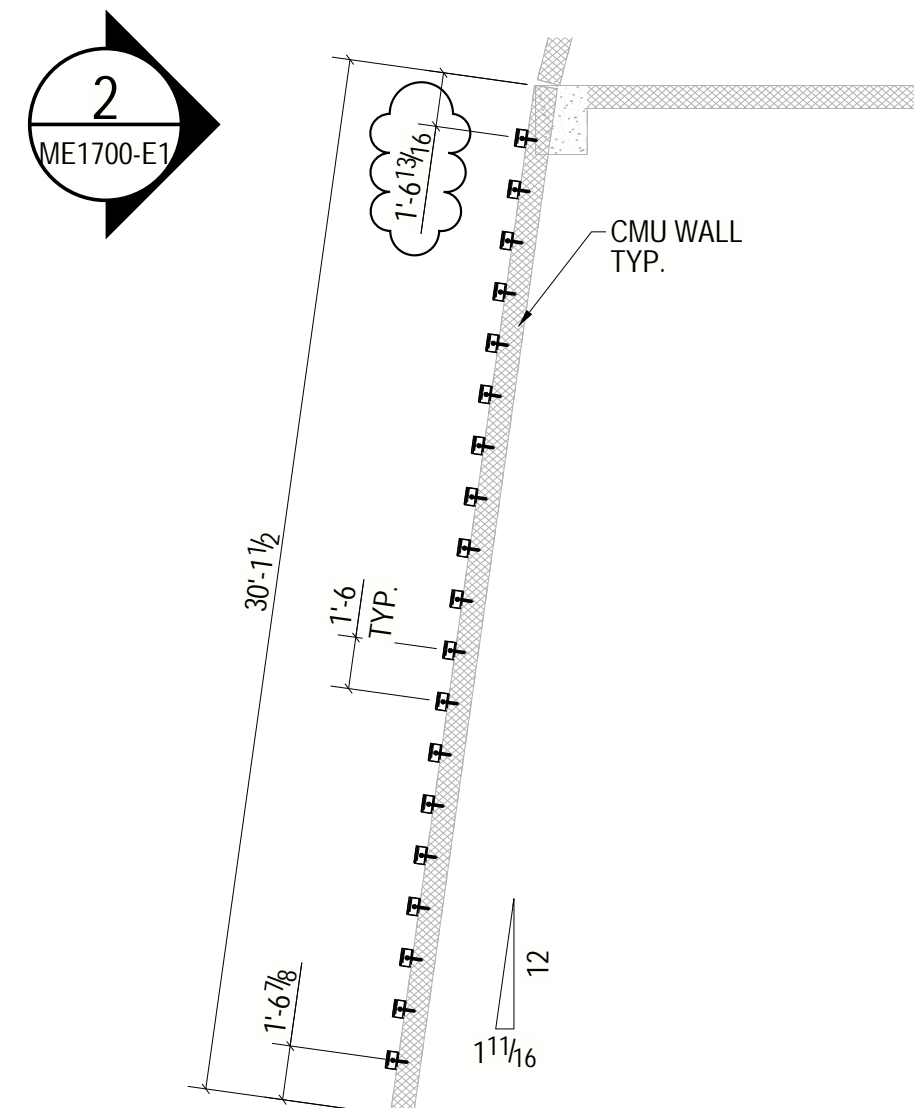
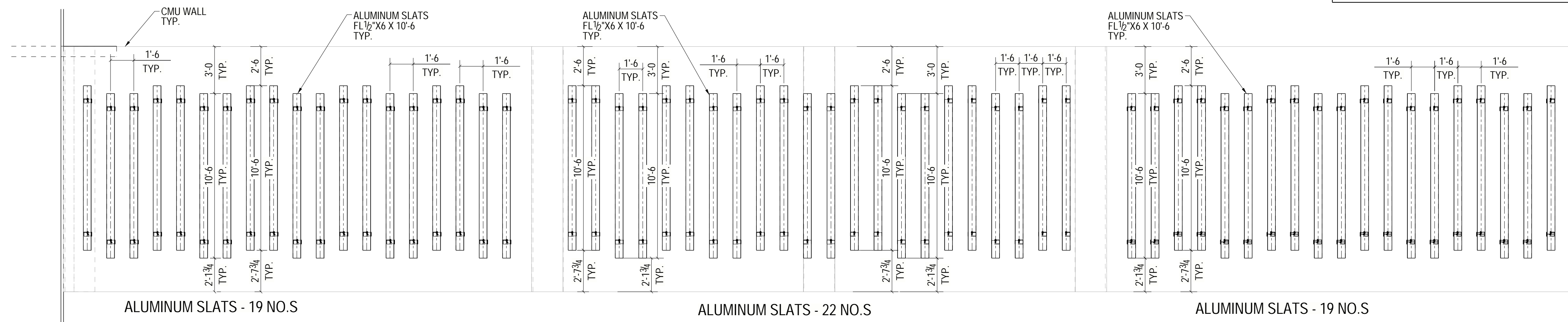

2 SECTIONAL ELEVATION
SCALE: 1:48

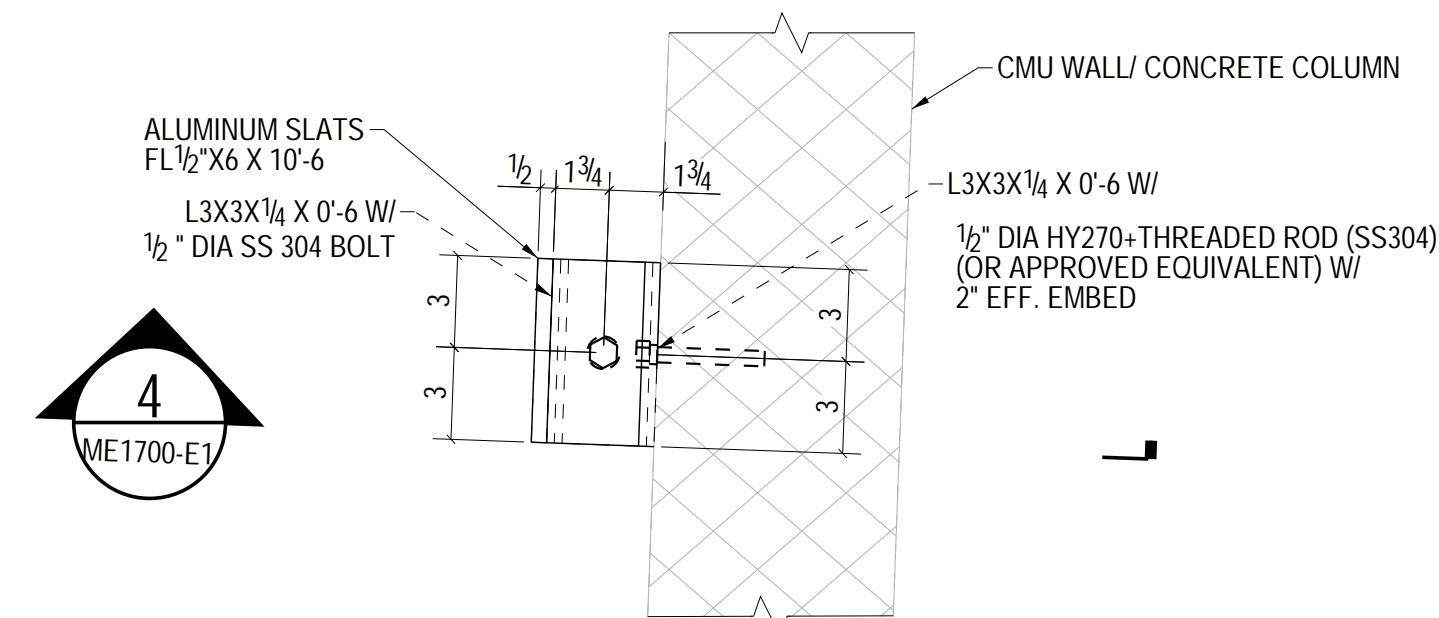

3 TYP. SLATS TO CMU WALL CONN.
SCALE: 1:6

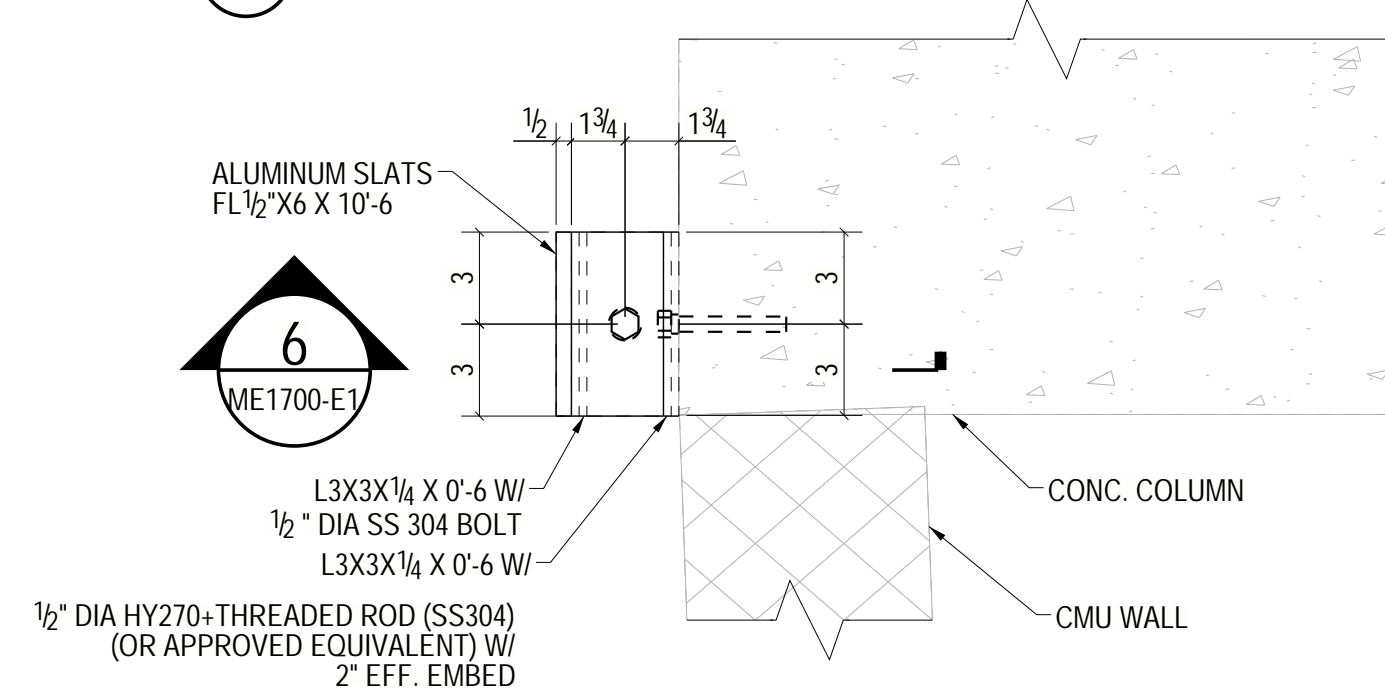

5 TYP. SLATS TO CONC. COLUMN CONN.
SCALE: 1:6

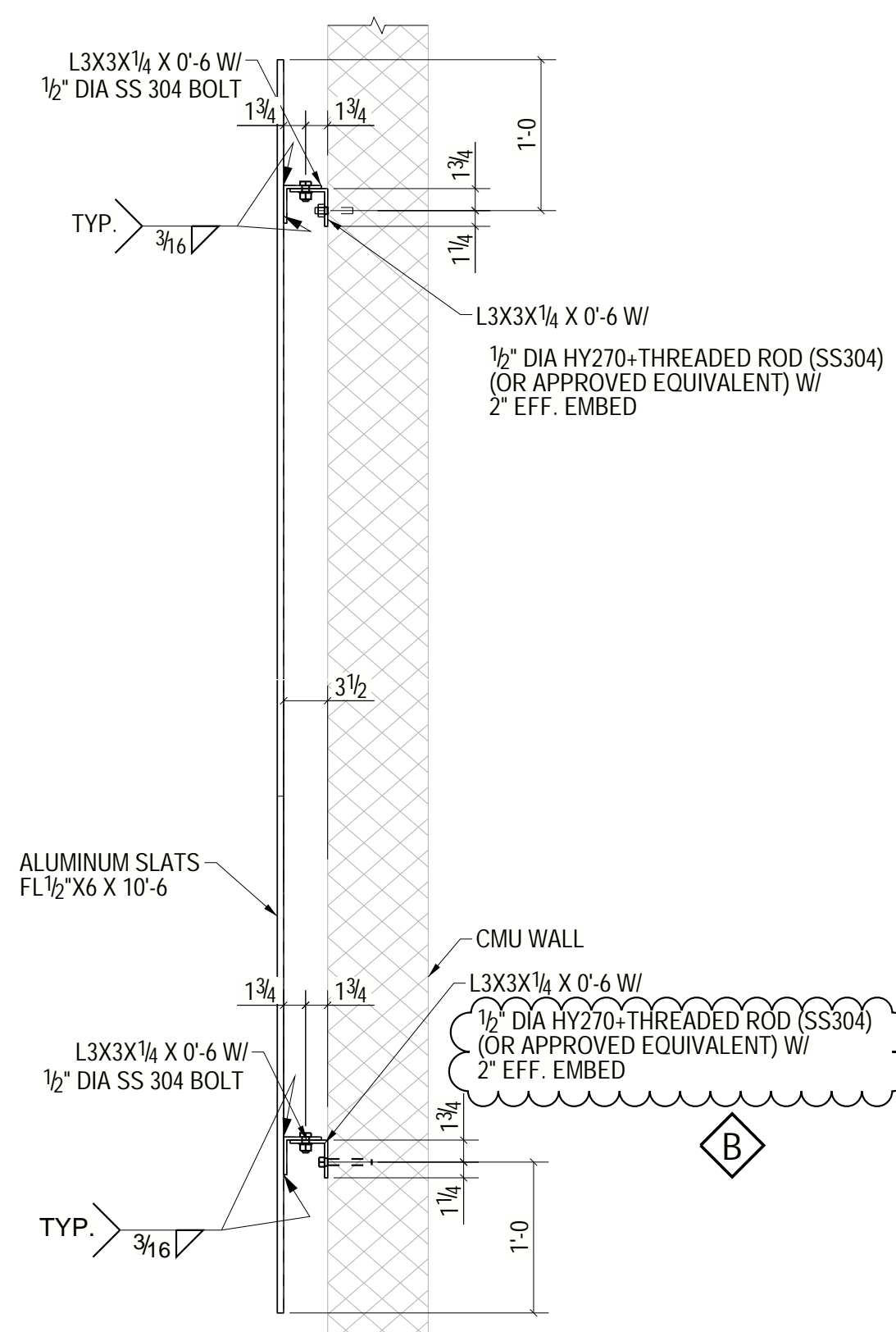

4 TYP. SECTION
SCALE: 1:12

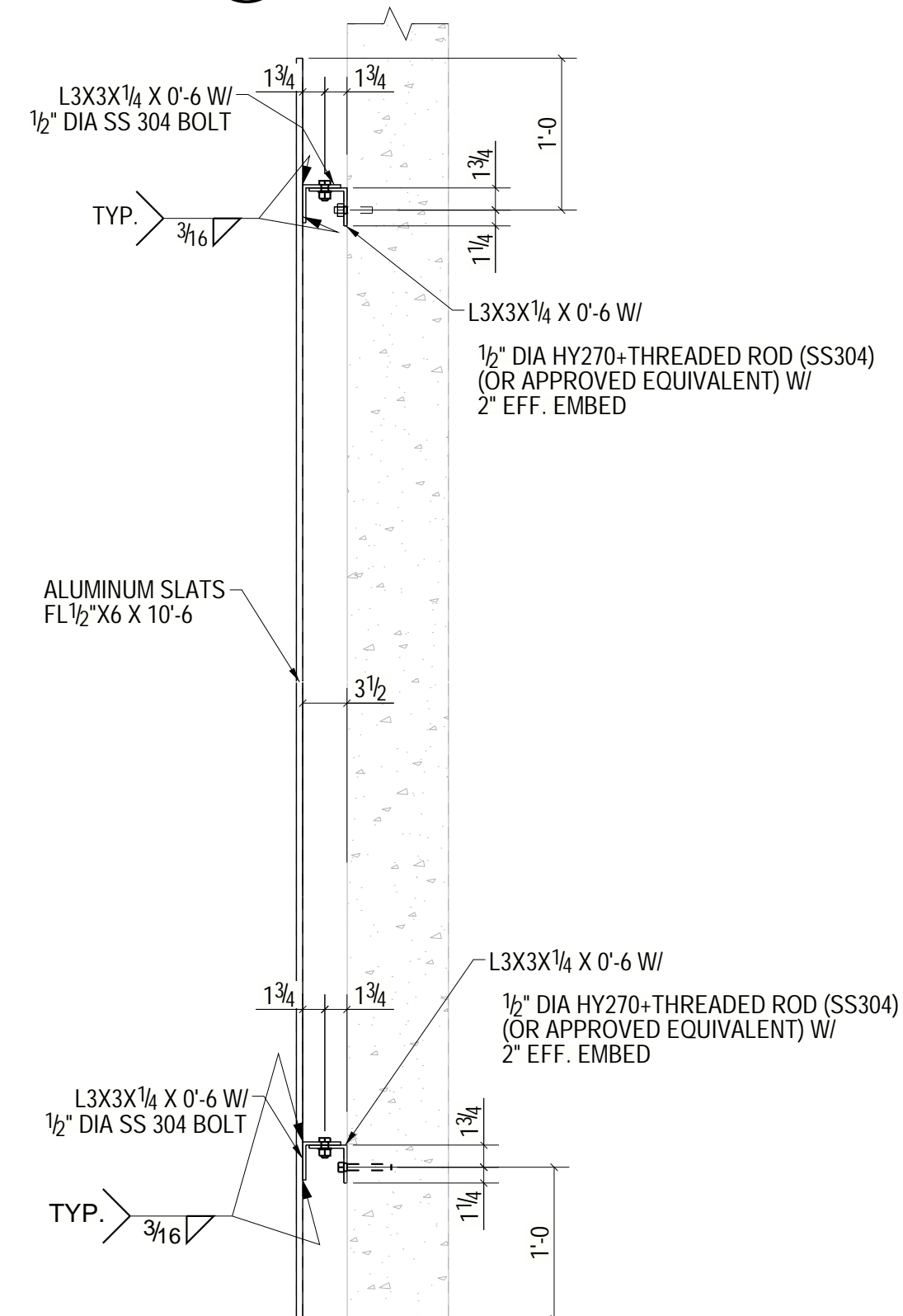

6 TYP. SECTION
SCALE: 1:12

ME1700-E1